

HICORP

Hydraulic Industrial Corporation of America

Valve Size	A	B	C	D	E*	F	G*	Weight
1-1/2" (150/300#)	6-3/8"	10"	3-15/16"	13-3/4"	20-3/16"	5"	5-1/2"	76#
2" (150/300#)	6-3/4"	12"	3-1/2"	13-3/4"	20-3/16"	7"	6-1/4"	99#
3" (150#)	7-3/4"	14"	4-1/4"	16-1/4"	22-3/4"	7"	6-3/4"	161#
3" (300#)	8-1/2"	14"	4-1/4"	17"	23-1/2"	7"	6-3/4"	200#
4" (150/300#)	10-1/4"	21"	5-3/8"	21"	28-3/4"	8-3/8"	7-7/8"	254#
6" (150#)	11-1/2"	26"	7-9/16"	25-1/4"	32-13/16"	9-7/8"	10"	431#
6" (300#)	13"	26"	7-9/16"	26-3/4"	34-1/8"	9-7/8"	10"	545#

* Approximate Dimensions

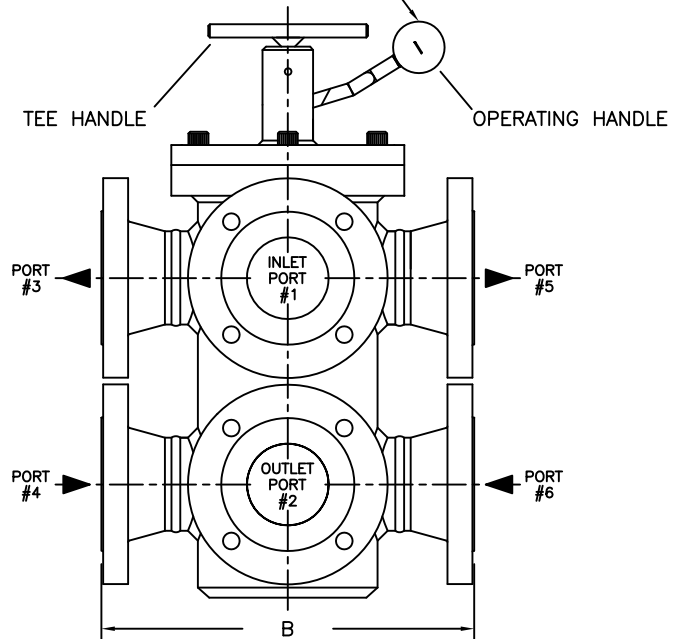
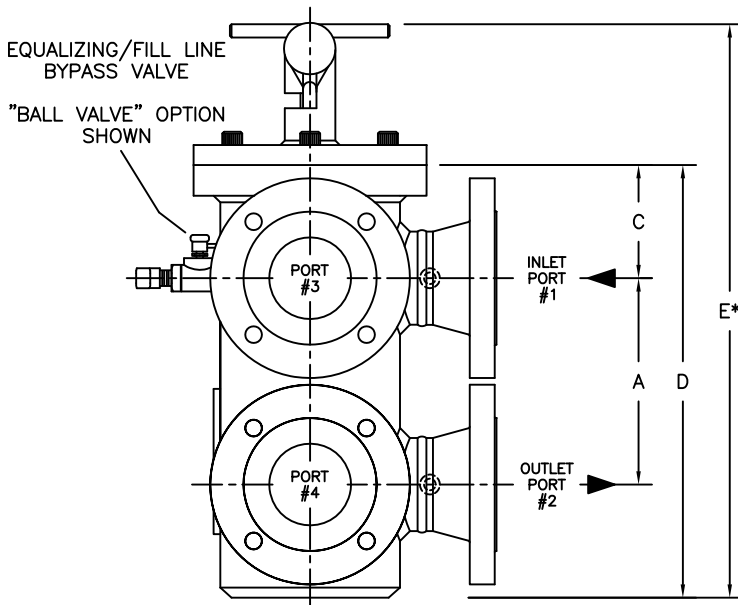
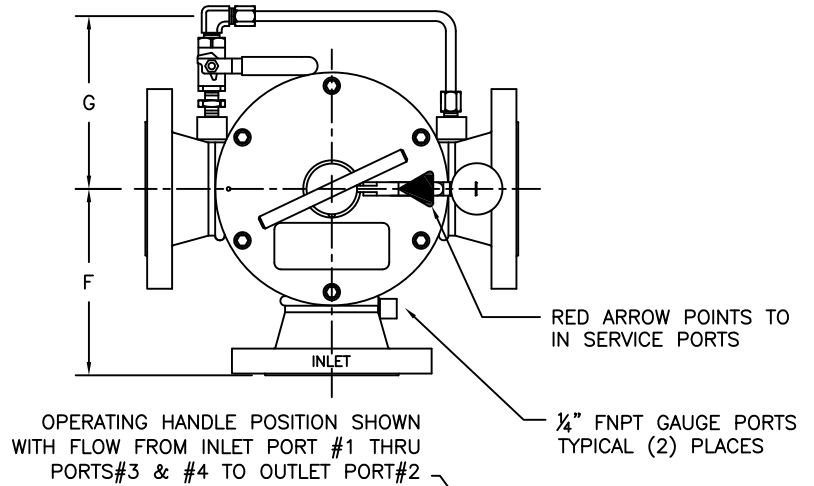
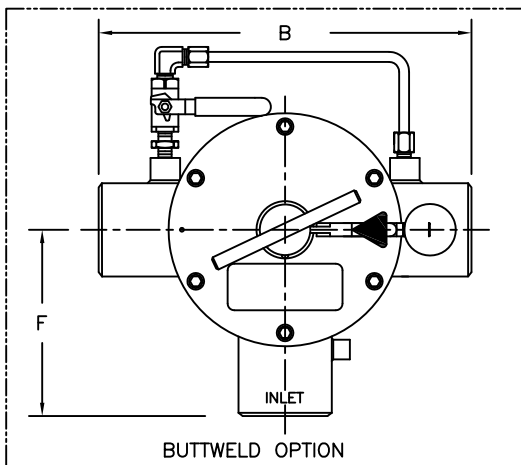

6 Way - Same Side Continuous Flow Transfer Valve

- * Standard Class 150 or 300# ASME B16.5 Flanges
- * Optional Buttweld Pipe Nozzles
- * Carbon Steel Construction - Optional Stainless Steel
- * Same Side Inlet / Outlet Porting

- * "No" Leak Design
- * Stainless Steel Operating Shaft Standard
- * Soft Seat Elastomer Sealing Pads
- * Customer Valve Designs Available - Consult Factory